

Description

Technical data

Return filter

Maximum working pressure up to 800 kPa (8 bar)

Flow rate up to 750 l/min

MPF is a range of return filters for protection of the reservoir against the system contamination.

They are directly fixed to the reservoir, in immersed or semi-immersed position.

The filter output must be always immersed into the fluid to avoid aeration or foam generation into the reservoir.

Available features:

- Female threaded connections up to 2" and flanged connections up to 2", for a maximum flow rate of 750 l/min
- Multiple connections, to connect several return lines or drains
- Fine filtration rating, to get a good cleanliness level into the reservoir
- Bypass valve integrated into the filter element, to relieve excessive pressure drop across the filter media
- 2, 3 or 4 fixing holes for installation, to suit a variety of reservoir surfaces
- O-ring or Flat Seal to suit a variety of reservoir surfaces
- Oil dipstick, to easily check the level of the fluid into the reservoir (sold as separate item)
- Extension tube, to be used in deep reservoirs (sold as separate item)
- Diffuser, to reduce the risk of aeration, foaming and noise (sold as separate item)
- Filler plug, to fill cleaned fluid into the tank without an additional connection
- Visual, electrical and electronic clogging indicators

Common applications:

- Light industrial equipment
- Mobile application

Filter housing materials

- Head: Aluminium
- Cover
Nylon: MPF 020-030-100-104-110
Aluminium: MPF 181-182-184-191-192-194-400-410-450-451-750
- Bowl: Nylon

Bypass valve

- Opening pressure 175 kPa (1.75 bar) ±10%
- Opening pressure 300 kPa (3 bar) ±10%

Δp element type

- Microfibre filter elements - series H: 10 bar
- Fluid flow through the filter element from OUT to IN

Seals

- Standard NBR series A
- Optional FPM series V

Temperature

From -25 °C to +110 °C

Note

MPF filters are provided for vertical mounting



Weights [kg] and volumes [dm³]

Filter series	Weights [kg]				Volumes [dm ³]					
	Length	1	2	3	4	Length	1	2	3	4
MPF 020		0.30	-	-	-		0.26	-	-	-
MPF 030		0.40	-	-	-		0.29	-	-	-
MPF 100		0.61	0.64	0.67	0.74		0.64	0.85	1.20	1.65
MPF 104		0.82	0.96	1.02	1.25		0.64	0.85	1.20	1.65
MPF 110		0.64	0.68	0.71	0.78		-	-	-	-
MPF 181		2.20	3.00	-	-		2.50	4.00	-	-
MPF 182		2.30	3.10	-	-		2.50	4.00	-	-
MPF 184		2.55	3.45	-	-		2.65	4.45	-	-
MPF 191		-	3.00	-	-		-	4.25	-	-
MPF 192		-	3.10	-	-		-	4.25	-	-
MPF 194		-	3.45	-	-		-	4.45	-	-
MPF 400		3.35	3.65	3.90	-		3.70	4.60	5.40	-
MPF 410		3.55	3.85	4.10	-		3.70	4.60	5.40	-
MPF 450-451		3.95	4.25	4.50	-		3.70	4.60	5.40	-
MPF 750		6.30	-	-	-		8.45	-	-	-

Filter series	Length	Filter element design - H series					Filter element design - N series		
		A03	A06	A10	A16	A25	M25 M60 M90	P10	P25
MPF 020	1	7	10	23	28	42	59	51	54
MPF 030	1	7	10	24	29	47	84	60	66
MPF 100-104-110	1	18	20	53	56	65	153	87	96
	2	28	38	65	75	95	158	111	123
	3	48	55	125	135	169	289	224	251
	4	79	89	180	185	198	306	264	289
MPF 181-182-184	1	127	148	235	243	278	441	285	299
	2	231	262	358	382	388	472	404	412
MPF 191-192-194	2	261	305	489	528	546	696	583	598
MPF 400	1	150	171	294	304	350	585	370	390
	2	237	252	454	462	589	868	619	645
	3	248	288	553	609	621	885	680	703
MPF 410	1	146	167	277	285	325	512	341	357
	2	226	239	396	402	485	644	503	519
	3	236	269	462	497	505	653	539	553
MPF 450-451	1	150	171	294	304	350	585	370	390
	2	237	252	454	462	589	868	619	645
	3	248	288	553	609	621	885	680	703
MPF 750	1	392	465	623	700	769	929	804	819

Maximum flow rate for a complete return filter with a pressure drop $\Delta p = 0.5$ bar.

The reference fluid has a kinematic viscosity of 30 mm²/s (cSt) and a density of 0.86 kg/dm³.

For different pressure drop or fluid viscosity we recommend to use our selection software available on www.mpfiltri.com.

You can also calculate the right size using the formulas present on the FILTER SIZING paragraph at the beginning of the full catalogue or at the beginning of the filter family brochure. Please, contact our Sales Department for further additional information.

Hydraulic symbols

Filter series	Style 1 connection	Style 2 connections
MPF 020	•	
MPF 030	•	
MPF 100	•	
MPF 104	•	
MPF 110		•
MPF 181	•	
MPF 182		•
MPF 184	•	•
MPF 191	•	
MPF 192	•	
MPF 194	•	•
MPF 400	•	
MPF 410		•
MPF 450	•	
MPF 451		•
MPF 750	•	

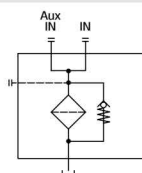
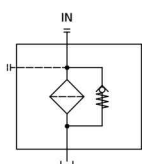

MPF GENERAL INFORMATION

Pressure drop

Filter housings Δp pressure drop

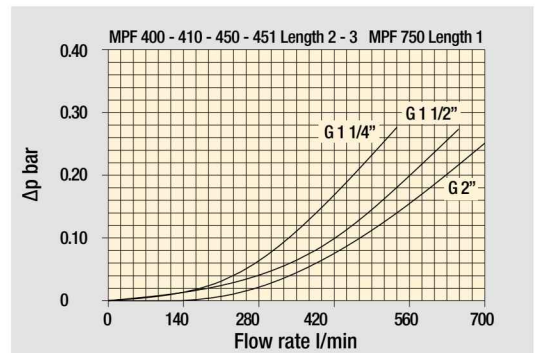
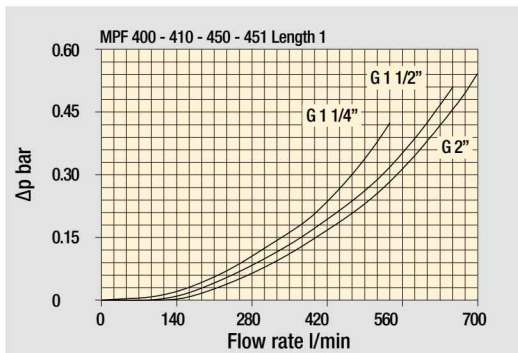
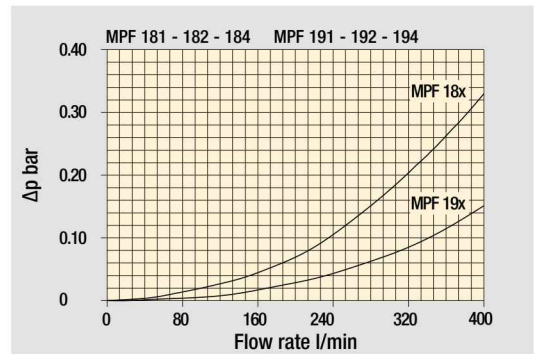
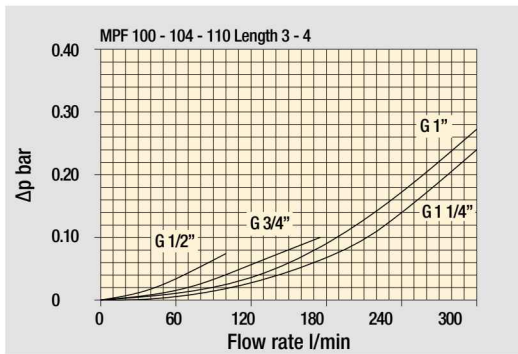
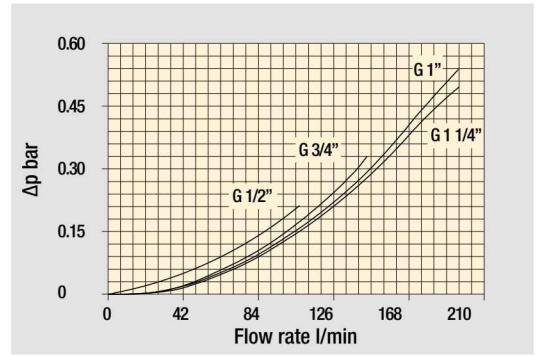
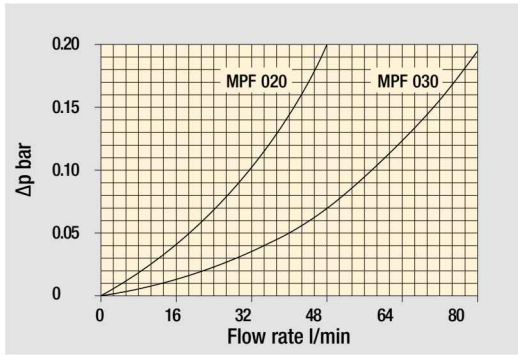

Bypass valve pressure drop

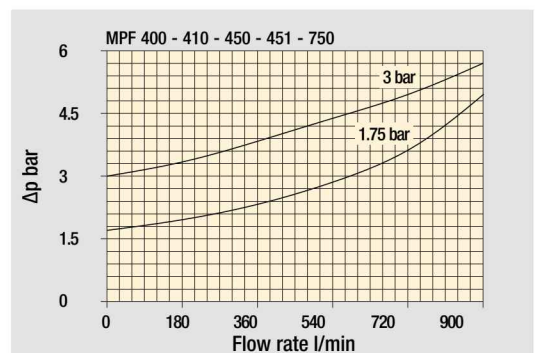
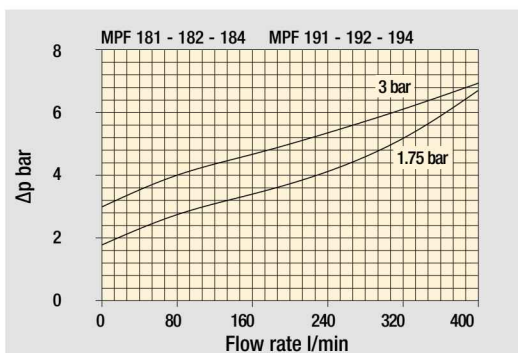
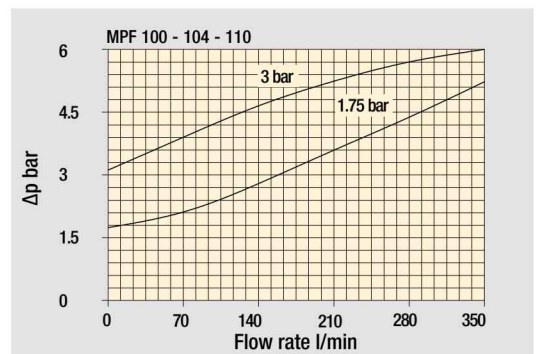
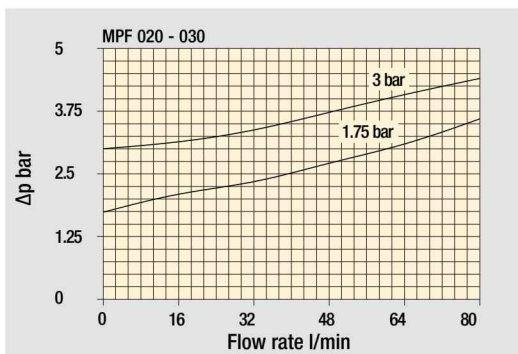

The curves are plotted using mineral oil with density of 0.86 kg/dm³ in compliance with ISO 3968. Δp varies proportionally with density.

Standard - Single IN port



Double IN port
Option: double indicator port

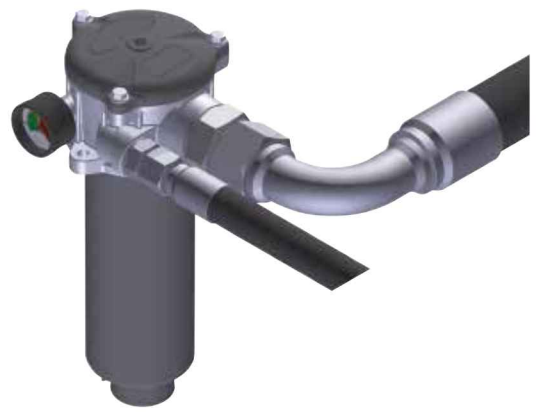

Double IN port - Drain port
Option: indicator port

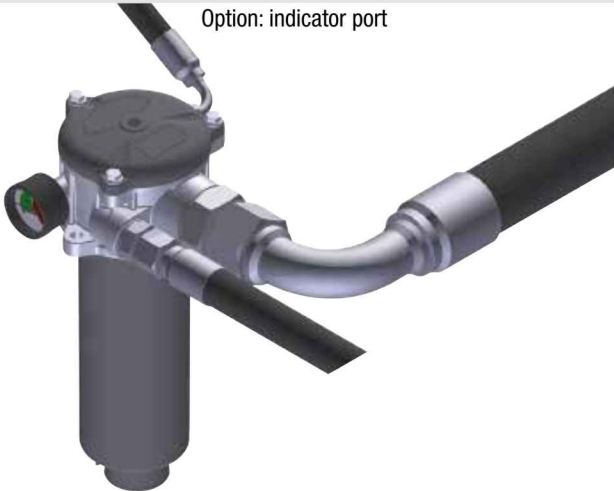

Double IN port - Double drain port

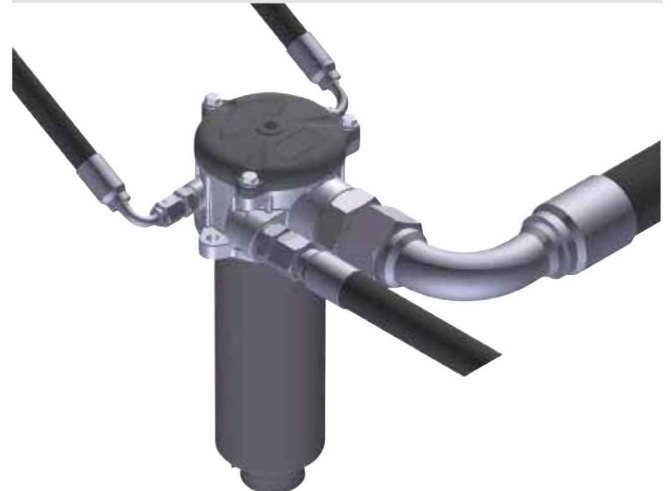

MPF MPF020 - MPF030

Designation & Ordering code

COMPLETE FILTER

Series and size	Configuration example 1: MPF020 1 A P1 A10 H E P01	
MPF020 MPF030 Filter element with standard spigot	Configuration example 2: MPF030 1 V G1 M25 N B P01	
Length	1	
Seals and treatments	A NBR V FPM W NBR head anodized Z FPM head anodized	
Connections	Size 20	Size 30
P1 Hose barb ø12	•	
G1 G 1/2"		•
G4 1/2" NPT		•
G7 SAE 8 - 3/4" - 16 UNF		•
Filtration rating (filter media)	A03 Inorganic microfiber 3 µm M25 Wire mesh 25 µm A06 Inorganic microfiber 6 µm M60 Wire mesh 60 µm A10 Inorganic microfiber 10 µm M90 Wire mesh 90 µm A16 Inorganic microfiber 16 µm P10 Resin impregnated paper 10 µm A25 Inorganic microfiber 25 µm P25 Resin impregnated paper 25 µm	
Element Δp	Filter media	
	Axx	Mxx Pxx
N 10 bar		• •
H 10 bar	•	
W 10 bar, compatible with fluids HFA, HFB and HFC	•	•
	Bypass valve	Execution
	E 3 bar	P01 MP Filtri standard
	B 1.75 bar	Pxx Customized

FILTER ELEMENT

Element series and size	Configuration example 1: MF030 1 A10 H B E P01	
MF030 Filter element with standard spigot	Configuration example 2: MF030 1 M25 N V P01	
Element length	1	
Filtration rating (filter media)	A03 Inorganic microfiber 3 µm M25 Wire mesh 25 µm A06 Inorganic microfiber 6 µm M60 Wire mesh 60 µm A10 Inorganic microfiber 10 µm M90 Wire mesh 90 µm A16 Inorganic microfiber 16 µm P10 Resin impregnated paper 10 µm A25 Inorganic microfiber 25 µm P25 Resin impregnated paper 25 µm	
Element Δp	Filter media	
	Axx	Mxx Pxx
N 10 bar		• •
H 10 bar	•	
W 10 bar, compatible with fluids HFA, HFB and HFC	•	•
	Seals	Bypass valve Execution
	B NBR	E 3 bar P01 MP Filtri standard
	V FPM	1.75 bar Pxx Customized

ACCESSORIES

Indicators	page		page
BVA Axial pressure gauge	240	BEA Electrical pressure indicator	239
BVR Radial pressure gauge	240	BEM Electrical pressure indicator	239
BVP Visual pressure indicator with automatic reset	241	BLA Electrical / visual pressure indicator	239-240
BVQ Visual pressure indicator with manual reset	241		
Additional features	page		
TE Extension tube	248		
T5 Filler plug M30x1.5	249		

