



### APPLICATION :

For use on steering of low speed vehicles, extensively used on such as forklifts, tractors, construction equipment, rudder of ship, mowers, mining and industrial positioning requirement.

### DESCRIPTION OF UNIT HSU(S) :

In load sensing steering system, the oil for steering system and working circuit may be supplied by pump via a priority valve in which can support extra amount of steering system oil into operating system. In addition when uses a pump with which is connected load reaction, energy of system will be saved.

A LS inlet of load sensing steering unit is connected with a priority valve or with a LS inlet of pump with load reaction. Via the oil hose the pressure signal of the steering load transfers from the steering unit to the priority valve or the pump with load reaction, so as to control the oil volume which is supplied to steering unit. In the neutral position of load sensing steering unit, only less than 2L/min oil of steering system direct to flow back to the tank.

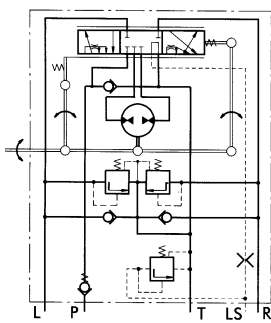

HSUS.../5. "Close Center"  
Non-Load Reaction - Load Sensing  
Manifold Mount

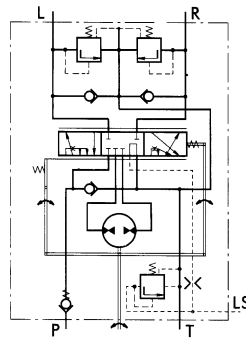

HSUS.../5T. "Close Center"  
Non-Load Reaction - Load Sensing  
Threaded Ports

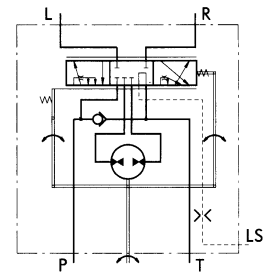

HSU.../5T. "Close Center"  
Non-Load Reaction - Load Sensing  
Threaded Ports

## Specifications

Parameters		Type									
		HSU HSUS 50/5(T)	HSU HSUS 63/5(T)	HSU HSUS 80/5(T)	HSU HSUS 100/5(T)	HSU HSUS 125/5(T)	HSU HSUS 160/5(T)	HSU HSUS 200/5(T)	HSU HSUS 250/5(T)	HSU HSUS 315/5(T)	HSU HSUS 400/5(T)
Displacement	cc/rev (cu.in)	50.8 (3.1)	62.9 (3.8)	79.8 (4.9)	99.6 (6.1)	124.5 (7.6)	159.6 (9.8)	199.4 (12.2)	249.2 (15.2)	316.5 (19.4)	399.7 (24.4)
Rated Flow	l/min (gpm)	5 (1.3)	6 (1.6)	8 (2.1)	9 (2.4)	11 (2.9)	15 (4)	17 (4.5)	24 (6.3)	30 (7.9)	40 (10.6)
Rated Pressure	bar (PSI)	160 (2320)									
Relief Valve Pressure Setting	bar (PSI)	80 (1160)		100 (1450)	120 (1740)	140 (2030)	160 (2320)				
Shock Valve Pressure Setting	bar (PSI)	140 (2030)		160 (2320)	180 (2610)	200 (2900)	220 (3190)				
Max. Cont. Pressure in Line T	bar (PSI)	20 (290)									
Max. Torque-Powered	Nm (lb.-in.)	5 (44)									
D Type Weight	kg (lb)	5.75 (12.68)	5.82 (12.83)	5.89 (12.99)	5.96 (13.14)	6.1 (13.45)	6.3 (13.89)	6.5 (14.33)	6.73 (14.98)	7.1 (15.65)	7.5 (16.53)
E Type Weight	kg (lb)	5.94 (13.31)	6.00 (13.47)	6.08 (13.62)	6.14 (13.82)	6.3 (14.11)	6.5 (14.55)	6.7 (14.97)	6.9 (15.48)	7.29 (16.29)	7.79 (17.17)
D Type Dimension L	mm (in.)	130 (5.12)	132 (5.2)	134 (5.28)	137 (5.39)	140 (5.51)	145 (5.71)	150 (5.91)	156 (6.14)	166 (6.54)	176 (6.93)
E Type Dimension L	mm (in.)	140 (5.51)	142 (5.59)	144 (5.67)	146 (5.75)	149 (5.87)	154 (6.06)	159 (6.26)	165 (6.5)	175 (6.89)	185 (7.28)

**D Type**

**Dimensions and Mounting Data HSUS.../5**

(Inch) show in brackets[]

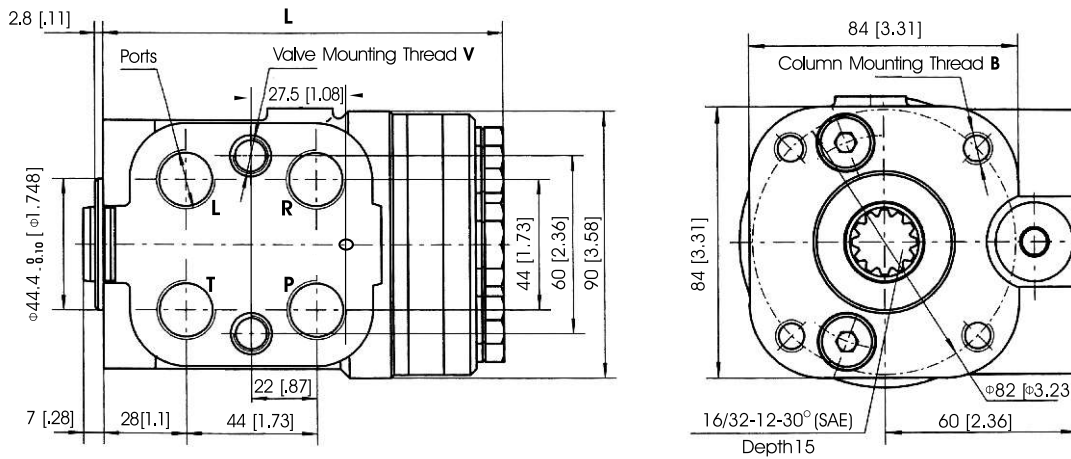

**Thread Ports**

Code	Ports – P, T, R, L Thread	Column Mounting Thread - B	Valve Mounting Thread - V	LS-Port
-	G 1/2 14 mm depth	4 x M10 x 1.5 16 mm depth	2 x M10 x 1 16 mm depth	G 1/4 12 mm depth
GA*	G 3/8 14 mm depth	4 x M10 x 1.5 16 mm depth	2 x M10 x 1 16 mm depth	G 1/4 12 mm depth
U	3/4 – 16UNF O-ring 14 mm depth	4 x 3/8 – 16UNC 0.63 [16] depth	2 x 3/8 – 24UNF 0.63 [16] depth	7/16 -20UNF 12 [0.55] depth
UA*	9/16 – 18UNF O-ring 14 mm depth	4 x 3/8 – 16UNC 0.63 [16] depth	2 x 3/8 – 24UNF 0.63 [16] depth	7/16 -20UNF 12 [0.55] depth
M	M22 - x 1.5 14 mm depth	4 x M10 x 1.5 16 mm depth	2 x M10 x 1 16 mm depth	G 1/4 12 mm depth

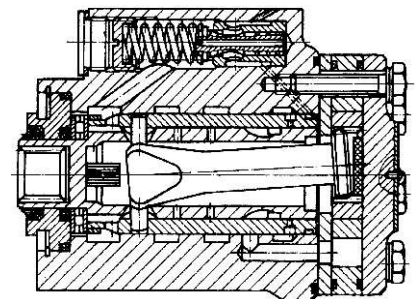

\* These threads are for displacements from HSUS50 to HSUS125 only.

**Dimensions and Mounting Data HSUS.../5T**

(Inch) show in brackets[]

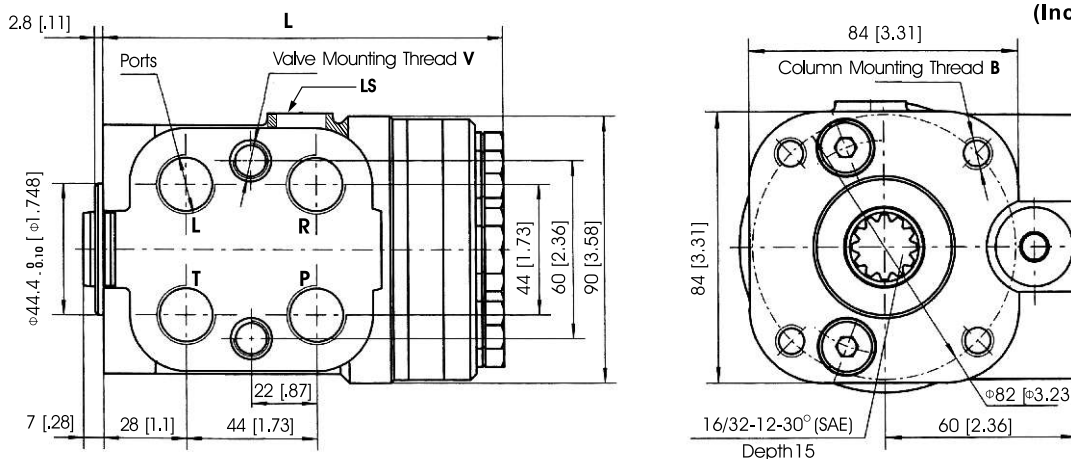

**E Type**

**Dimensions and Mounting Data HSUS.../5**

(Inch) show in brackets[ ]

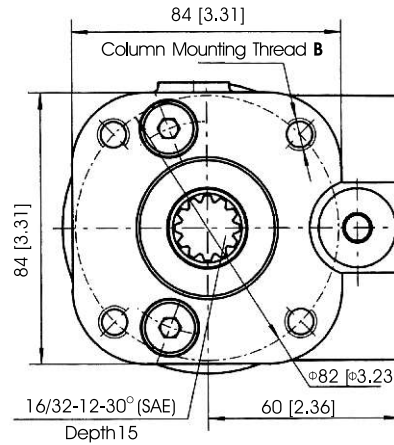
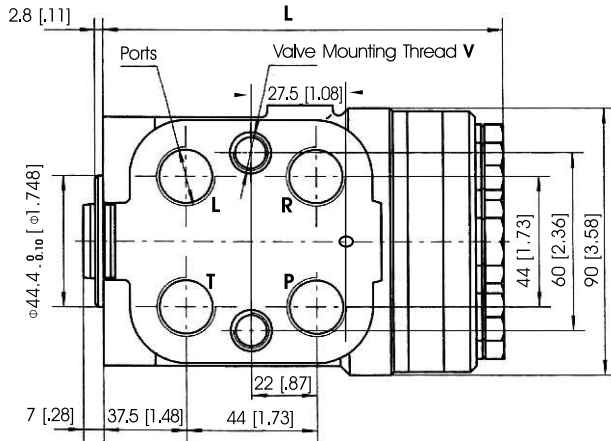

**Thread Ports**

Code	Ports – P, T, R, L Thread	Column Mounting Thread - B	Valve Mounting Thread - V	LS-Port
-	G 1/2 14 mm depth	4 x M10 x 1.5 16 mm depth	2 x M10 x 1 16 mm depth	G 1/4 12 mm depth
GA*	G 3/8 14 mm depth	4 x M10 x 1.5 16 mm depth	2 x M10 x 1 16 mm depth	G 1/4 12 mm depth
U	3/4 – 16UNF O-ring 14 mm depth	4 x 3/8 – 16UNC 0.63 [16] depth	2 x 3/8 – 24UNF 0.63 [16] depth	7/16 -20UNF 12 [0.55] depth
UA*	9/16 – 18UNF O-ring 14 mm depth	4 x 3/8 – 16UNC 0.63 [16] depth	2 x 3/8 – 24UNF 0.63 [16] depth	7/16 -20UNF 12 [0.55] depth
M	M22 - x 1.5 14 mm depth	4 x M10 x 1.5 16 mm depth	2 x M10 x 1 16 mm depth	G 1/4 12 mm depth

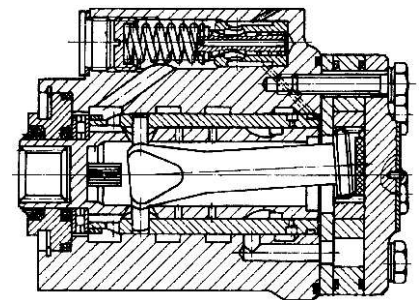

\* These threads are for displacements from HSUS50 to HSUS160 only.

**Dimensions and Mounting Data HSUS.../5T**

(Inch) show in brackets[ ]

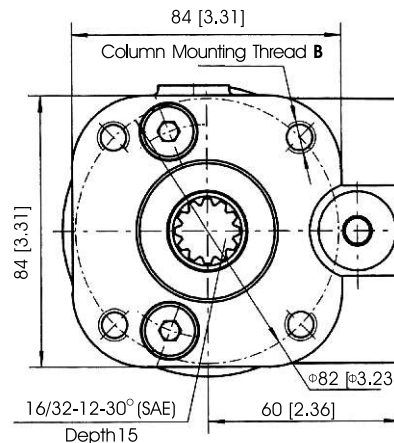
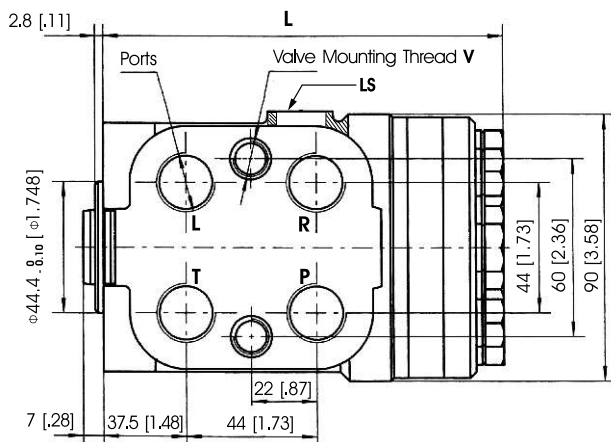

### D Type

### Dimensions and Mounting Data HSU.../5T

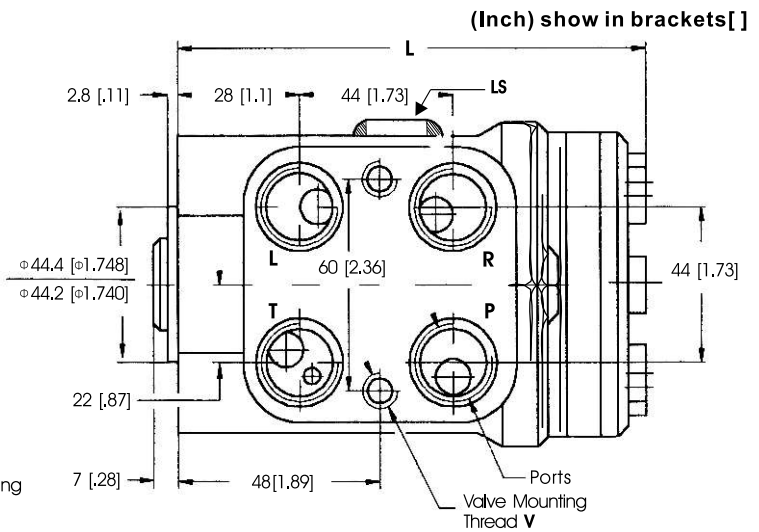
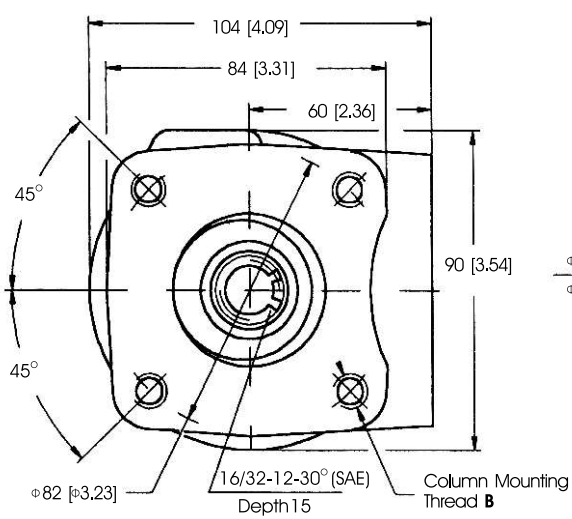

### Thread Ports

Code	Ports – P, T, R, L Thread	Column Mounting Thread - B	Valve Mounting Thread - V	LS-Port
-	G 1/2 14 mm depth	4 x M10 x 1.5 16 mm depth	2 x M10 x 1 16 mm depth	G 1/4 12 mm depth
GA*	G 3/8 14 mm depth	4 x M10 x 1.5 16 mm depth	2 x M10 x 1 16 mm depth	G 1/4 12 mm depth
U	3/4 – 16UNF O-ring 14 mm depth	4 x 3/8 – 16UNC 0.63 [16] depth	2 x 3/8 – 24UNF 0.63 [16] depth	7/16 -20UNF 12 [0.55] depth
UA*	9/16 – 18UNF O-ring 14 mm depth	4 x 3/8 – 16UNC 0.63 [16] depth	2 x 3/8 – 24UNF 0.63 [16] depth	7/16 -20UNF 12 [0.55] depth
M	M22 - x 1.5 14 mm depth	4 x M10 x 1.5 16 mm depth	2 x M10 x 1 16 mm depth	G 1/4 12 mm depth

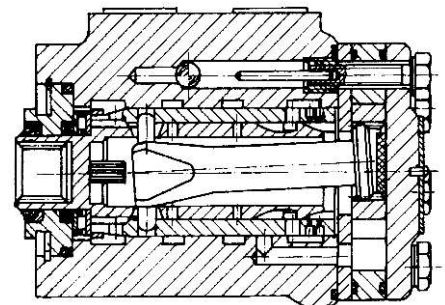

\* These threads are for displacements from HSU50 to HSU125 only.

### E Type

### Dimensions and Mounting Data HSU.../5T

(Inch) show in brackets [ ]

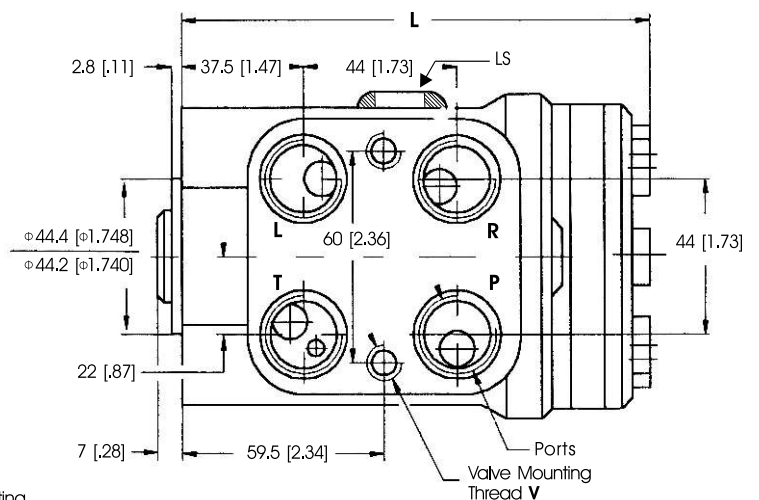
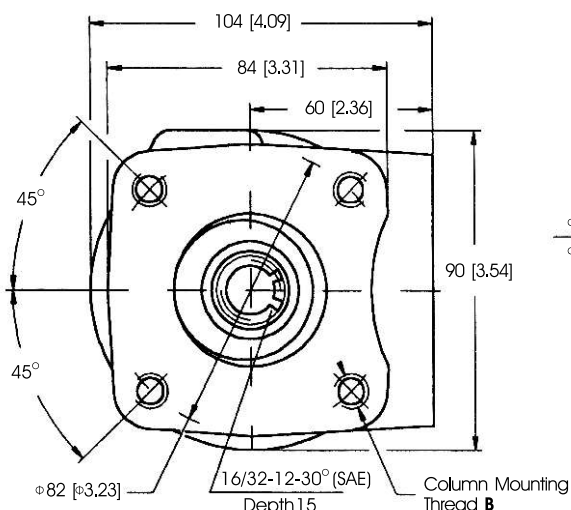

### Ordering Information

	1	2	3	4	5	6	7
<b>HSUS</b>		/	5	-	-		

**Pos.1 Displacement Code**

50	-	50.8cc / 3.1 [in.3/r]
63	-	62.9cc / 3.8 [in.3/r]
80	-	79.8cc / 4.9 [in.3/r]
100	-	99.6cc / 6.1 [in.3/r]
125	-	124.5cc / 7.6 [in.3/r]
160	-	159.6cc / 9.8 [in.3/r]
200	-	199.4cc / 12.2 [in.3/r]
250	-	249.2cc / 15.2 [in.3/r]
315	-	316.5cc / 19.4 [in.3/r]
400	-	399.7cc / 24.4 [in.3/r]

**Pos.2 Versions Code**

5	-	Version 5 "Cloas Cneter - Non Reaction and Load Sensing Outlet"
---	---	---

**Pos.3 Priority Valves Connection**

Omit	-	Modulary Mounting
T	-	Pipe Mounting

**Pos.4 LS - Valve Pressure Settings, bar(PSI)**

80	-	80 [1160]
100	-	100 [1450]
120	-	120 [1740]
140	-	140 [2030]
160	-	160 [2320]

**Pos.5 Ports Code**

Omit	-	G 1/2
GA	-	G 3/8
U	-	3/4 - 16 UNF "O" Ring
UA	-	9/16-18 UNF "O" Ring
M	-	Metric

**Pos.6 Type Code**

Omit	-	D Type
E	-	E Type

**Pos.7 Design Series**

Omit	-	Factory specified
------	---	-------------------

	1	2	3	4	5	6
<b>HSU</b>		/	5	T	-	

**Pos.1 Displacement Code**

50	-	50.8cc / 3.1 [in.3/r]
63	-	62.9cc / 3.8 [in.3/r]
80	-	79.8cc / 4.9 [in.3/r]
100	-	99.6cc / 6.1 [in.3/r]
125	-	124.5cc / 7.6 [in.3/r]
160	-	159.6cc / 9.8 [in.3/r]
200	-	199.4cc / 12.2 [in.3/r]
250	-	249.2cc / 15.2 [in.3/r]
315	-	316.5cc / 19.4 [in.3/r]
400	-	399.7cc / 24.4 [in.3/r]

**Pos.2 Versions Code**

5	-	Version 5 "Closed Center - Non Reaction and Load Sensing Outlet"
---	---	--

**Pos.3 Priority Valves Connection**

T	-	Pipe Mounting
---	---	---------------

**Pos.4 Ports Code**

Omit	-	G 1/2
GA	-	G 3/8
U	-	3/4 - 16 UNF "O" Ring
UA	-	9/16-18 UNF "O" Ring
M	-	Metric

**Pos.5 Type Code**

Omit	-	D Type
E	-	E Type

**Pos.6 Design Series**

Omit	-	Factory specified
------	---	-------------------