

final pump - series XV

FINAL PUMP TO BE COUPLED WITH XV2
FEMALE Ø36,5 FLANGE

X1F-2

X 1 F 25 82 T I I A

Series	X	series XV
Group	1	group 1
Category	F	final pump
Displacement	25	3.8
Flange	82	Ø36.5 female right rotation 2P+1P, 3P+1P
Shaft	T	SCF01 - Final
Body	IN	inlet - Ø30 Ø12 M6
	OUT	outlet - Ø30 Ø12 M6
Cover	A	standard

X2T
X2I-2
X3T
X3I-3



XF103

Technical data table

TYPE	Displacement cm3/rev	Max. Pressure		CODE																	
		P1 bar	P3 bar	Left rotation			Right rotation														
X1F-2/0.9	0,91	240	280	X	1	F	16	81	T	I	I	A	X	1	F	16	82	T	I	I	A
X1F-2/1.2	1,17	250	290	X	1	F	17	81	T	I	I	A	X	1	F	17	82	T	I	I	A
X1F-2/1.7	1,56	250	290	X	1	F	18	81	T	I	I	A	X	1	F	18	82	T	I	I	A
X1F-2/2.2	2,08	250	290	X	1	F	20	81	T	I	I	A	X	1	F	20	82	T	I	I	A
X1F-2/2.6	2,60	250	300	X	1	F	21	81	T	I	I	A	X	1	F	21	82	T	I	I	A
X1F-2/3.2	3,12	250	300	X	1	F	23	81	T	I	I	A	X	1	F	23	82	T	I	I	A
X1F-2/3.8	3,64	250	300	X	1	F	25	81	T	I	I	A	X	1	F	25	82	T	I	I	A
X1F-2/4.3	4,16	250	300	X	1	F	27	81	T	I	I	A	X	1	F	27	82	T	I	I	A
X1F-2/4.9	4,94	250	300	X	1	F	29	81	T	I	I	A	X	1	F	29	82	T	I	I	A
X1F-2/5.9	5,85	250	300	X	1	F	31	81	T	I	I	A	X	1	F	31	82	T	I	I	A
X1F-2/6.5	6,50	250	300	X	1	F	32	81	T	I	I	A	X	1	F	32	82	T	I	I	A
X1F-2/7.8	7,54	220	260	X	1	F	34	81	T	I	I	A	X	1	F	34	82	T	I	I	A
X1F-2/9.8	9,88	190	230	X	1	F	36	81	T	I	I	A	X	1	F	36	82	T	I	I	A

P1) Max. working pressure - P3) Max. peak pressure

For heavy-duty applications, it is recommended to check the admissible torque of the shaft

Dimensions table

TYPE	Weight kg	A	B	D	E	F	D	E	F
		mm	mm	IN			OUT		
X1F-2/0.9	0,950	81,5	40,8	Ø12	30	M6x1	Ø12	30	M6x1
X1F-2/1.2	0,970	82,5	41,3	Ø12	30	M6x1	Ø12	30	M6x1
X1F-2/1.7	1,010	84,0	42,0	Ø12	30	M6x1	Ø12	30	M6x1
X1F-2/2.2	1,030	86,0	43,0	Ø12	30	M6x1	Ø12	30	M6x1
X1F-2/2.6	1,060	88,0	44,0	Ø12	30	M6x1	Ø12	30	M6x1
X1F-2/3.2	1,090	90,0	45,0	Ø12	30	M6x1	Ø12	30	M6x1
X1F-2/3.8	1,120	92,0	46,0	Ø12	30	M6x1	Ø12	30	M6x1
X1F-2/4.3	1,170	94,0	47,0	Ø12	30	M6x1	Ø12	30	M6x1
X1F-2/4.9	1,200	97,0	48,5	Ø12	30	M6x1	Ø12	30	M6x1
X1F-2/5.9	1,260	100,5	50,3	Ø12	30	M6x1	Ø12	30	M6x1
X1F-2/6.5	1,300	103,0	51,5	Ø12	30	M6x1	Ø12	30	M6x1
X1F-2/7.8	1,360	107,0	53,5	Ø12	30	M6x1	Ø12	30	M6x1
X1F-2/9.8	1,500	116,0	58,0	Ø12	30	M6x1	Ø12	30	M6x1

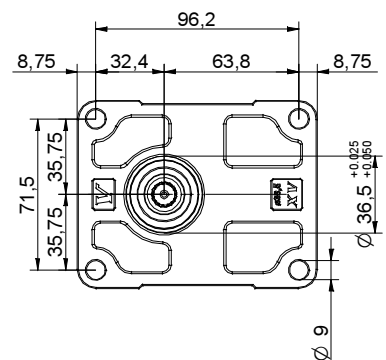
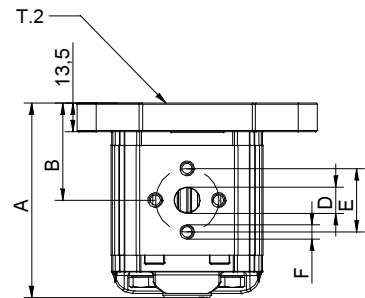
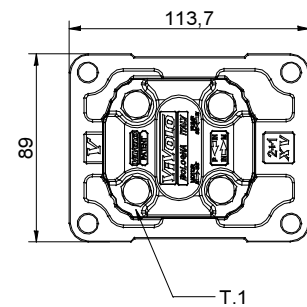

01/04/08 XF2582TIIA.dft

T.1 = 24.5±29.4 [Nm] - screw tightening torque M8

T.2 = 42.8 [Nm] - admissible shaft torque (N.B. When choosing a shaft, always check the admissible torque).

Table of variations

X1F-2

Female $\varnothing 36.5$ FLANGE

Female $\varnothing 36.5$ FLANGE		Shaft	
Left rotation	Right rotation		
		SCF01 - Splined T.2 = 42.8 [Nm] m=0,75 Z=15	T
81	82		

Cover		
Left rotation	Right rotation	
		A
		B
		C
		D
		N
		O

Displacement	
TYPE	CODE
X1F-2/0.9	16
X1F-2/1.2	17
X1F-2/1.7	18
X1F-2/2.2	20
X1F-2/2.6	21
X1F-2/3.2	23
X1F-2/3.8	25
X1F-2/4.3	27
X1F-2/4.9	29
X1F-2/5.9	31
X1F-2/6.5	32
X1F-2/7.8	34
X1F-2/9.8	36

Standard bodies							
Displacement cm3/rev	Standard threads						
	0.9	I - I	B - B	J - J	B - Z	Z - Z	G - F
1.2	I - I	B - B	J - J	B - Z	Z - Z	G - F	
1.7	I - I	B - B	J - J	B - Z	Z - Z	G - F	
2.2	I - I	B - B	J - J	B - Z	Z - Z	G - F	
2.6	I - I	B - B	J - J	B - Z	Z - Z	G - F	
3.2	I - I	B - B	J - J	B - Z	Z - Z	G - F	
3.8	I - I	B - B	J - J	B - Z	Z - Z	G - F	
4.3	I - I	B - B	J - J	B - Z	Z - Z	G - F	
4.9	I - I	B - B	J - J	B - Z	Z - Z	G - F	
5.9	I - I	B - B	J - J	B - Z	Z - Z	G - F	
6.5	I - I	B - B	J - J	B - Z	Z - Z	G - F	
7.8	I - I	B - B	J - J	B - Z	Z - Z	G - F	
9.8	I - I	B - B	J - J	B - Z	Z - Z	G - F	

Table showing standard flange and thread combinations available in stock

Body (threads/flanges)													
	A		B		C		D		E		F		G
	H		I		J	Closed Body	Z						