

VERSION DESCRIPTION

RV-D FLOW DIVIDER

This is the flow divider standard version, it simply divide the incoming flow without allowing the phase correction

RV-S FLOW DIVIDER with single phase correction valve

This version has just one phase correction valve for all the elements, it can obviously divide the flow and allow the phase correction, but only in the direction of flow division.

RV-V FLOW DIVIDER with phase correction and anticavitation valves

In this version the flow divider has one phase correction and anticavitation valve for each element, this allow a flow correction in both direction (flow division and flow unification). In addition it can adjust the relief pressure to a different value for each element.

RV-G FLOW DIVIDER + MOTOR

The RV-G typology is the motorized version of the RV-D divider.

It has a motor conneted to the flow divider elements. This solution is important when the incoming and/or outgoing pressure is below the minimum pressure required to start. Giving flow to the motor, help the flow divider rotation start. Typical use: plants with single effects hydraulic jack.

RV-H FLOW DIVIDER with single phase correction valve + MOTOR

This is the motorized version of the RV-S divider.

The motor has the same fonction that is described for the RV-G divider.

RV-N FLOW DIVIDER with phase correction and anticavitation valve + MOTOR

This is the motorized version of the RV-V divider.

The motor has the same fonction that is described for the RV-G divider.

The flow division error is lower than $\pm 1.5\%$ with a pressure difference between one element and another until 30 Bars. For bigger differences we can approximate an error increase of 1 % for each 10 additional bars.

RV-0

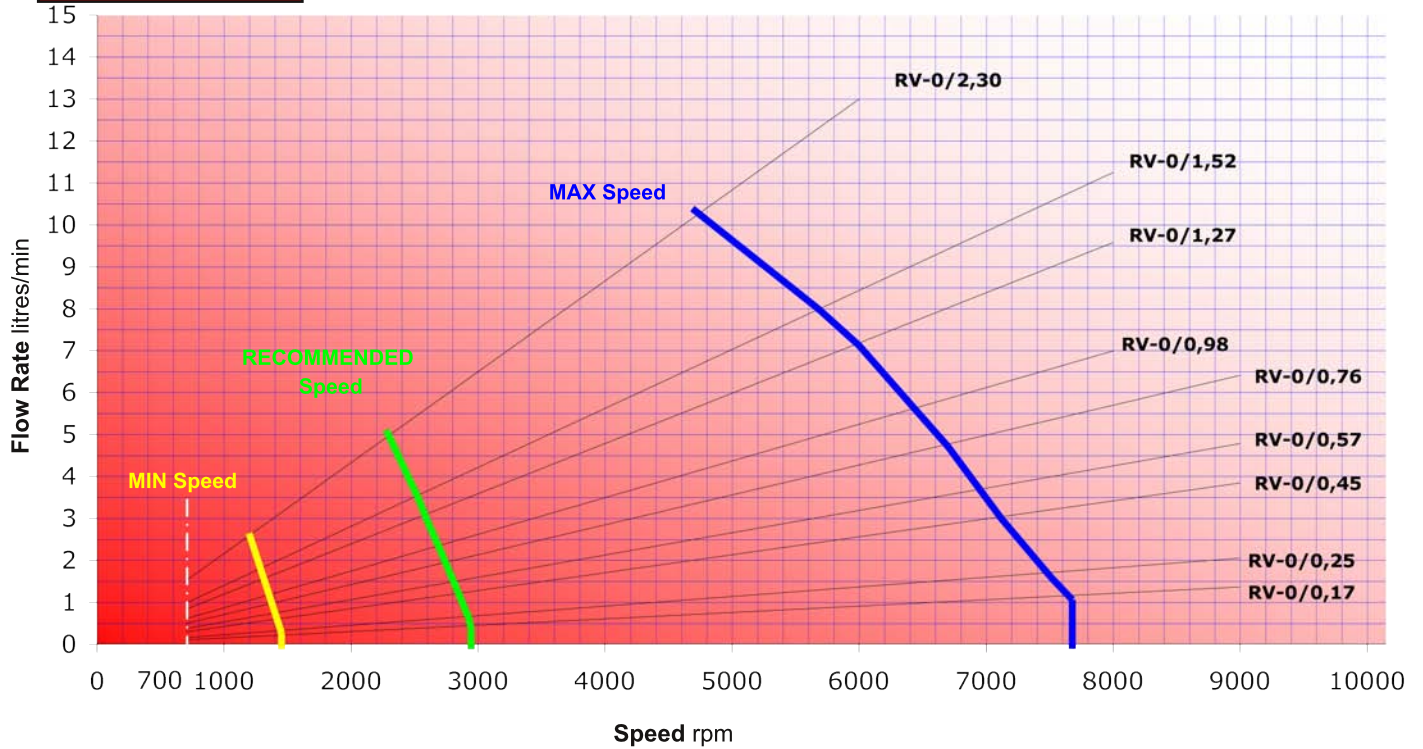

RV-1

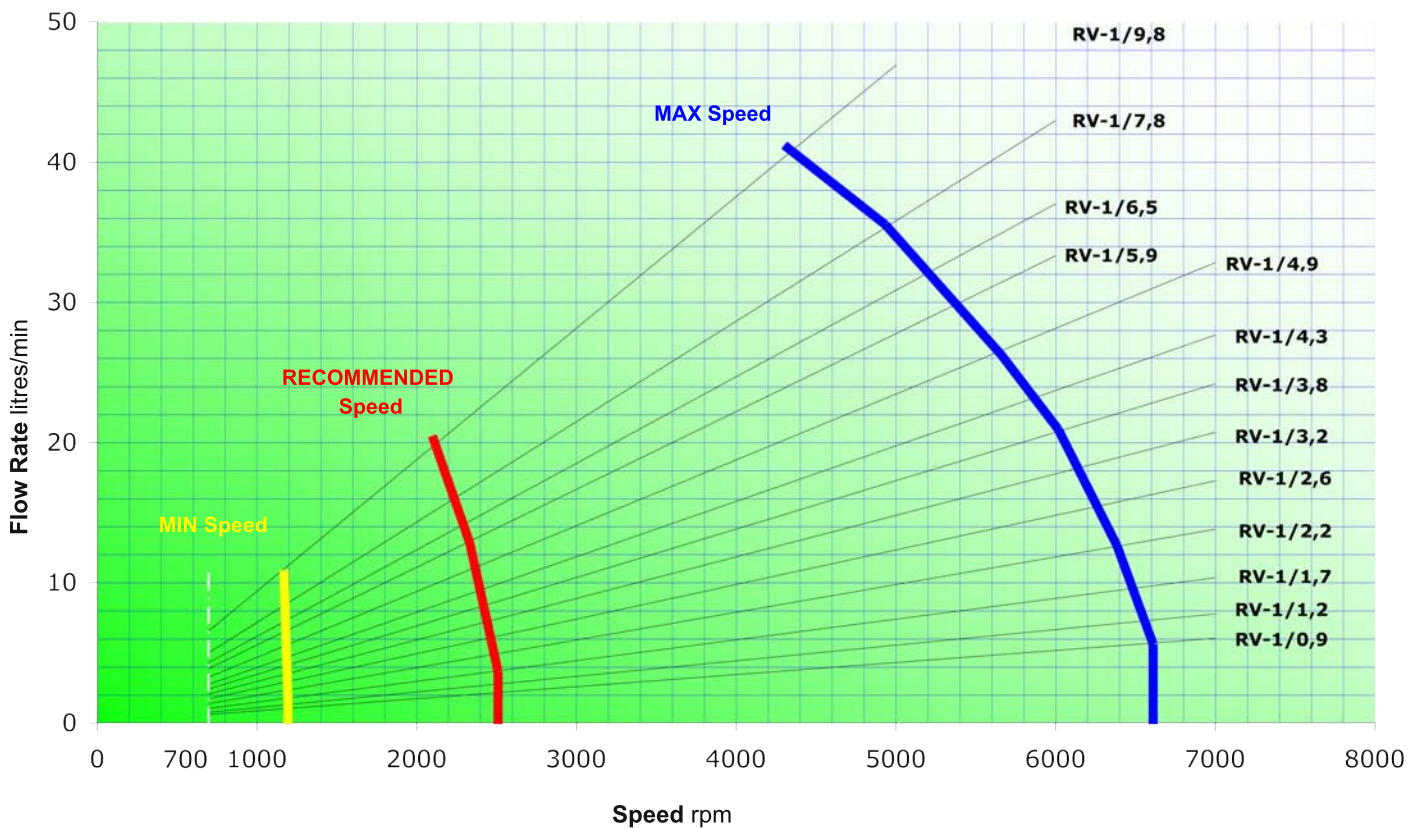

NOTE: the flow divider can work even below the minimum speed, but it's efficiency will be lower
the flow divider can work even over the maximum speed, but it will increase the noise and loss of load

Flow divider with **single phase correction valve** common to all the elements

Code:

9RS NN M CC

9RD	Flow Divider Typology
NN	Number of elements
M	Code of setting range of the valves
CC	Displacement Code

TABLE "M"	
C	10 ÷ 105 bar
D	70 ÷ 210 bar
E	140 ÷ 350 bar

Example: Flow divider with two elements (same displacement)
RV-1S / 3,8 x 2 with valve 10 ÷ 105 bar

9RS 02 C 25

Example: Flow Divider with 4 elements (with different displacement - max 7):
RV-1S / 3,8+4,9+4,9+6,5 with valve 70 ÷ 210 bar

9RS 04 D 25 29 29 32

NOTE: to define codes for flow dividers with more than 7 different displacement, please contact our sales department.

Table: 1

Displacem. Cm ³ /rev	CC Code	Max Pressure bar	One element flow rate l/min		
			MIN	RECOMMENDED	MAX
0,9	16	220	1	2	6
1,2	17	220	1,5	3	7
1,7	18	220	2	4	9
2,2	20	220	2,5	5	13
2,6	21	220	3	6	15,5
3,2	23	220	3,5	7,5	18
3,8	25	220	4	8,5	21
4,3	27	220	4,5	9,5	23
4,9	29	220	5,5	11	27
5,9	31	220	6,5	13	30
6,5	32	220	7,5	14	32
7,8	34	210	8,5	16	35,5
9,8	36	200	11	20	41

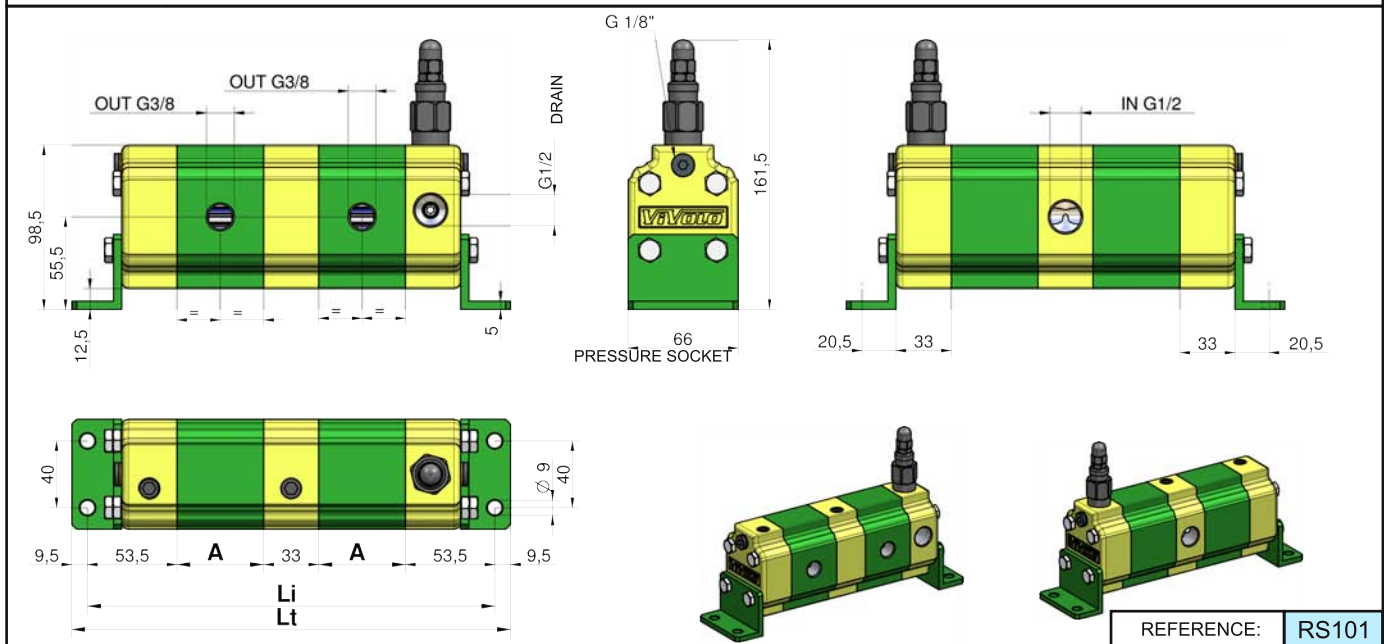

Table: 2

Li = Distance between fixing hole centres (single displacement flow divider)

Cm ³ /rev	A	Number of elements														
		2	3	4	5	6	7	8	9	10	11	12	13	14	15	16
0,9	41,5	223	297,5	372	446,5	521	595,5	670	744,5	819	893,5	968	1042,5	1117	1191,5	1266
1,2	42,5	225	300,5	376	451,5	527	602,5	678	753,5	829	904,5	980	1055,5	1131	1206,5	1282
1,7	44	228	305	382	459	536	613	690	767	844	921	998	1075	1152	1229	1306
2,2	46	232	311	390	469	548	627	706	785	864	943	1022	1101	1180	1259	1338
2,6	48	236	317	398	479	560	641	722	803	884	965	1046	1127	1208	1289	1370
3,2	50	240	323	406	489	572	655	738	821	904	987	1070	1153	1236	1319	1402
3,8	52	244	329	414	499	584	669	754	839	924	1009	1094	1179	1264	1349	1434
4,3	54	248	335	422	509	596	683	770	857	944	1031	1118	1205	1292	1379	1466
4,9	57	254	344	434	524	614	704	794	884	974	1064	1154	1244	1334	1424	1514
5,9	60,5	261	354,5	448	541,5	635	728,5	822	915,5	1009	1103	1196	1289,5	1383	1476,5	1570
6,5	63	266	362	458	554	650	746	842	938	1034	1130	1226	1322	1418	1514	1610
7,8	67	274	374	474	574	674	774	874	974	1074	1174	1274	1374	1474	1574	1674
9,8	76	292	401	510	619	728	837	946	1055	1164	1273	1382	1491	1600	1709	1818

Table: 3 in this table the number of inlets in function of the number of elements are indicated.

Number of elements	2	3	4	5	6	7	8	9	10	11	12	13	14	15	16
"IN" Number of inlets	1	1	2	2	3	3	4	4	5	5	6	6	7	7	8

Flow divider with **single phase correction valve** common to all the elements

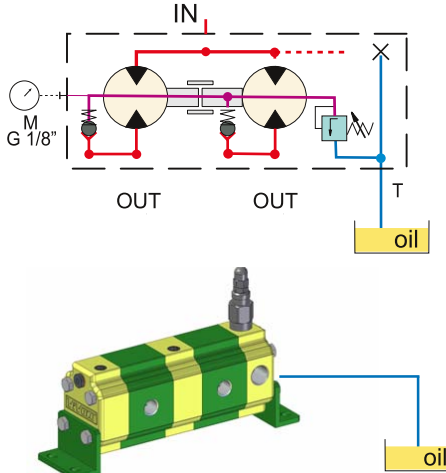
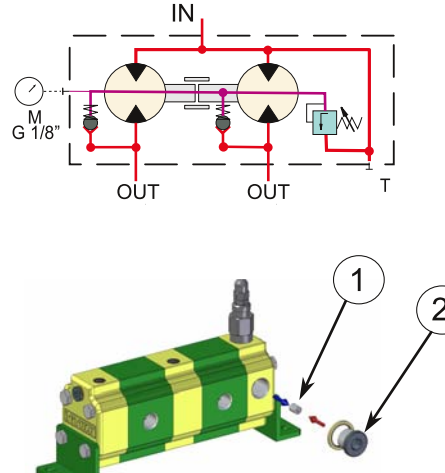
EXTERNAL DRAIN <i>STANDARD SETUP</i>	INTERNAL DRAIN
<p>Connect the drain port (T) to the tank</p>	<p>To predispose the divider to the internal drain, execute following operations:</p> <ol style="list-style-type: none"> 1. remove the G 1/8 dowel inside the drain port 2. with a 1/2 G plug, plug the drain port (T)
	

In **table 1** the functioning range of single flow divider elements is indicated.

The higher is the feeding capacity (q), the higher is the precision of the flow division, but in opposition there are losses of loading and higher noise. Therefore we suggest to feed the elements with capacities equal or a few superior to the ones indicated in the column **"RECOMMENDED"**.

Remember to verify the capacities even in phase of flow reunion.

The pressure indicated are to be considered as maximum of functioning, the flow divider is able to bear peaks of pressure 20 % superior.

How to calculate the "Li" and "Lt" measures of flow dividers:

From **table 2** it is possible to obtain the "Li" measure for flow dividers up to 16 elements with equal displacements; for flow dividers with different elements or with more than 16 elements the "Li" and "Lt" measure have to be calculated by the following formula:

$$Li = [(n-1) \times 33] + 107 + (A1 + A2 + A3 + \dots)$$

$$107 = 53,5 + 53,5$$

n = Number of elements of flow divider

A1... An = heights of elements of flow divider

$$Lt = Li + 19$$

$$19 = 9,5 + 9,5$$

EXAMPLE: To obtain the measures **Li** and **Lt** of a flow divider with three elements (n=3), **RV-1S 4.3 + 2.2 + 0.9**

Distance between fixing hole centres

$$Li = [(3-1) \times 33] + 107 + 54 + 46 + 41,5 = 314,5 \text{ mm}$$

Total Length

$$Lt = 314,5 + 19 = 333,5$$

In **table 3** the number of inlets in function of the number of elements are indicated.

For flow dividers with many inlets, as they are all communicating it is even possible to use only one of them, by plugging the other ones. We suggest to make full use at least of **1** inlet every **40 l/min** capacity.

To obtain errors of division **inferior to 3%** there must be no difference of pressure between the elements superior to **30 bar**. To obtain high precisions the respect of the following parameters is also important:

- Environment temperature: -10°C ÷ +60°C Oil temperature: +30°C ÷ +60°C
- Hydraulic oil based on hlp, hv (din 51524) minerals Oil Viscosity 20 ÷ 40 cSt
- Oil filtering 10 ÷ 25 µ