

Variable Displacement Vane Pump

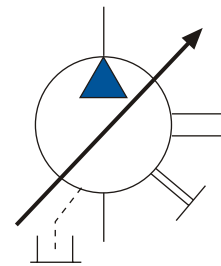

SYMBOL

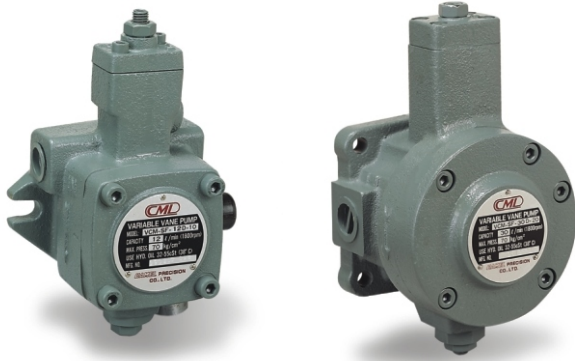

Model Code

VCM - SF - 20 - B - 10

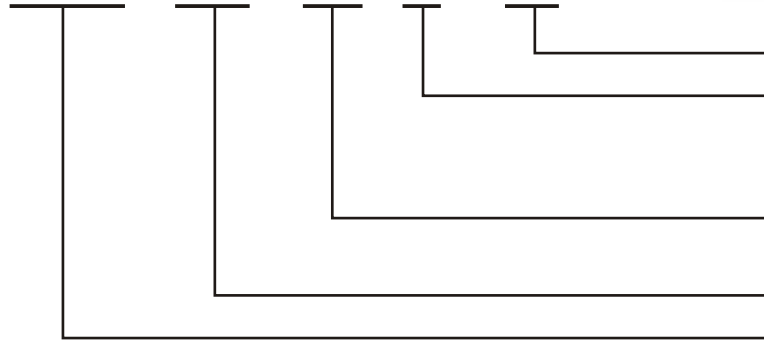

Design No.	
Pressure range	
A:20kgf/cm ²	C:55 kgf/cm ²
B:35kgf/cm ²	D:70 kgf/cm ²
Displacement at 1800 rpm	
12L,20L,30L,40L	12L, 20L, 30L, 40L
Series No.	
Vane Pump Series	

FEATURE:

1. High efficiency operation with minimum power loss.
2. Very low noise when operating.
3. Compactness and simple design, space saving and easy operation.
4. Sturdy structure for high efficiency and long service life.

Double Pump Ordering Code

VCM - DF - 30 - B/30- B - 10

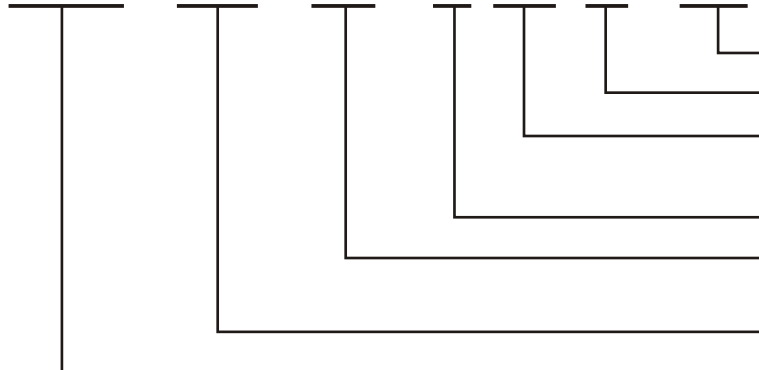

Design No.	
Secondary Pump Pressure	
Secondary Pump Displacement	
12L,20L,30L,40L	12L,20L,30L,40L
Shaft end Pump Pressure	
Shaft end Pump Displacement	
12L,20L,30L,40L	12L,20L,30L,40L
Series No.	
Vane Pump Series	

Variable Displacement Vane Pump

Technical Data

MODEL	Delivery at no load L/min		Pressure Adj Range kgf/cm ²	Shaft Speed rpm		Max Pressure kgf/cm ²	Weight Kg Flange
	1800rpm	1500rpm		Max	Min		
SF-12A	12	10	10-20	1800	800	20	5.0
SF-12B			15-35			35	
SF-12C			30-55			55	
SF-12D			50-70			70	
SF-20A	20	17	10-20	1800	800	20	5.0
SF-20B			15-35			35	
SF-20C			30-55			55	
SF-20D			50-70			70	
SF-30A	30	25	10-20	1800	800	20	9.0
SF-30B			15-35			35	
SF-30C			30-55			55	
SF-30D			50-70			70	
SF-40A	40	35	10-20	1800	800	20	9.0
SF-40B			15-35			35	
SF-40C			30-55			55	
SF-40D			50-70			70	

/ Performance Curve

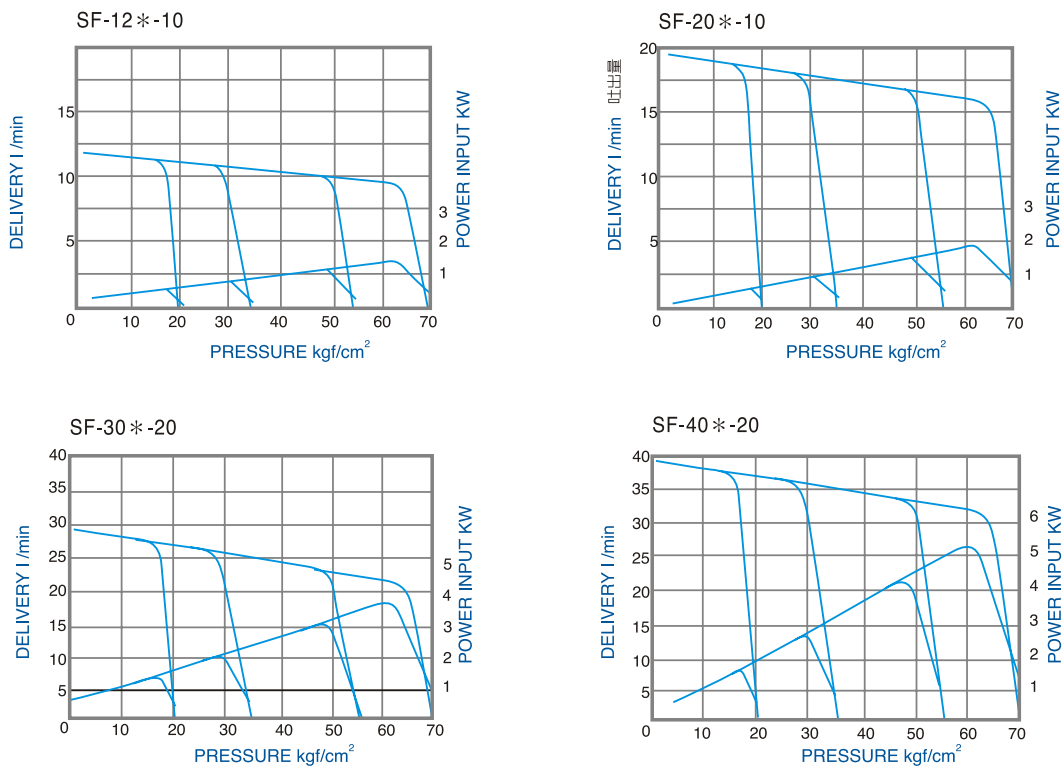

Variable Displacement Vane Pump

- SF-12※-10
- SF-20※-10

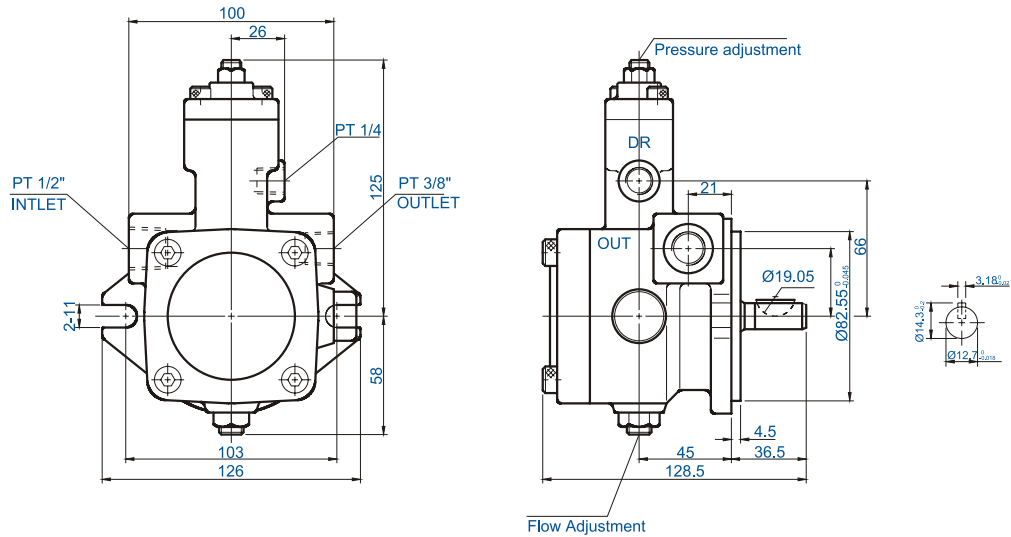

- SF-30※-20
- SF-40※-20

